



LORS / TECNA®

1090 LOUSONS ROAD ♦ UNION, NEW JERSEY 07083 USA
 Tel: 908-964-9100 ♦ Fax: 908-964-4492 ♦ email: sales@lors.com

INSTRUCTIONS FOR HEAVY DUTY BALANCERS MODELS: 9361-9371

ITEM	 		  		
	Kg.	Kg.	215	250	240
9361	10-15	10.3	>25	>25	
9362	15-20	10.6			
9363	20-25	11.2			
9364	25-30	11.5			
9365	30-35	11.8			
9366	35-40	12.4			
9367	45-55	12.5			
9368	55-65	13.6			
9369	65-75	14.5			
9370	75-90	17.3			
9371	90-105	18			

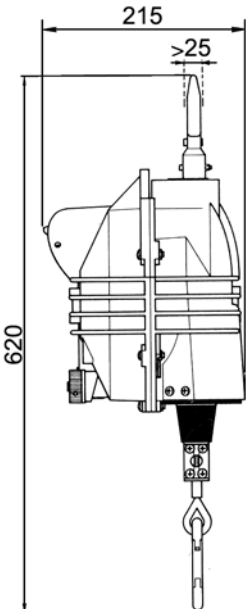
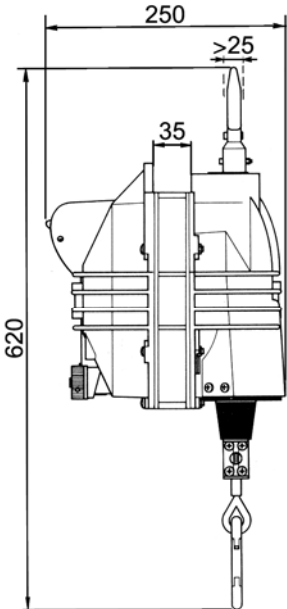
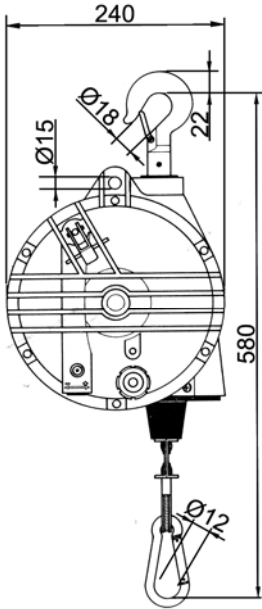
< 70 dB (A)

Save these instructions for all the balancer life. Safety connections N. 2 20331 N. 1 20332



CAREFULLY READ THIS MANUAL BEFORE INSTALLING AND OPERATING THE WELDER. IMPORTANT SAFETY INFORMATION ENCLOSED. READ THIS MANUAL BEFORE OPERATING BALANCER. IT IS THE RESPONSIBILITY OF THE EMPLOYER TO PLACE THE INFORMATION IN THIS MANUAL INTO THE HANDS OF THE OPERATOR. FAILURE TO OBSERVE THE FOLLOWING WARNINGS COULD RESULT IN INJURY.

FORESEEN USE

- Models 9361-9371 heavy duty balancers are designed to counter-balance the weight of tools.
- TECNA S.P.A. is not responsible for customers using these balancers for other applications on which TECNA S.P.A. was not consulted.

PLACING BALANCER IN SERVICE



This balancer can be used in an assembly line or in single working places.

- Always operate, inspect and maintain this balancer in accordance with all regulations referring to balancers, tools and to working places.
- Calculate the total load to balance: tool, accessories and those sections of hose or cable to be lifted by the balancer. The whole load to be balanced must be within the specified capacity range of the chosen balancer.
- To achieve the best performances, hang the balancer by means of hook (17) at a height which allows the use of the central section of the cable stroke. The balancer can be suspended from a fixed point or from a traverse system which is perfectly horizontal. **To avoid anomalous wear the balancer must always be free to rotate and line up with the cable (14), even when the load is not in a vertical line with the balancer.**



Always connect by means of the equipment accessories the suspension (S) of the balancer to a support having the proper dimensions. This support MUST NOT BE the same the hook (17) is connected to. Leave a maximum extra stroke of 100 mm (DIN 15112). Pay attention to both the fixing of the accessory cable 20332 which must be carefully doubled leaving a maximum extra stroke of 100 mm, and to clamp 20331 which must block both the two sections of the doubled cable. Repeat the tightening of the clamp after the first grasp by means of a suggested torque of 4 Nm; by doing so it is possible to tighten the yielding taking place between cable and clamps during the first locking phase. (see Fig. 1).



If screwed fasteners are used to connect the balancer or to fix the safety device to point (S), either self locking systems and/or split pins should be used.

- Hang the load on the hook (31).
- Do not lubricate balancers with flammable or volatile liquids.
- Do not remove any label. Replace any damaged label.

OPTIONS

OPTION "B", control from the floor. It enables the operator to directly operate both load locking and unlocking of the stroke at the required height.

- By pulling the **RED** side down the stroke is locked.
- By pulling the **GREEN** side down the balancer stroke is released.



Never unlock the drum by pulling the GREEN SIDE down if the load is not attached to the balancer. The cable could rewind at a dangerous speed causing injury.

- **OPTION "RI", lower swivel type hook and insulating device.** This rotation device avoids cable (17) twisting and is recommended in case of works requiring continuous load turnings and can be used when it is necessary to insulate the load from the balancer in order to avoid current circulation inside cable (17) (Fig. 3).

(Always operate in accordance with the safety electrical regulations).

To assemble it: disassemble hook (35) and insert in into the lower swivel type hook on pin side B; disassemble pin side A; insert cable (17) thimble; insert the cotter pin (D) deforming it as shown on fig. 3.

- **OPTION "B"** Should be required when ordering.
- **OPTION "RI"** (item 70477) can be required later on.

SAFETY WARNINGS AND ADJUSTMENTS



Never unlock the balancer by means of either knob (1) (Fig. 5) or control from the floor (48) (Fig. 2) when the cable is extended and not attached to the load. Cable (14) could rewind at a dangerous speed causing injury and damaging the balancer.



Never restore safety lock cam (4) (Fig. 6) without having first verified what caused the block.



During these interventions, always leave the load attached and place a support preventing from dropping.



Never touch the spring of the assembly (13) even in case of maintenance.

The spring-drum assembly (13) is supplied already assembled and, in case of breakage, it must be entirely replaced. This enables to both restore the balancer original efficiency and reduce the maintenance terms.

- **Centrifugal safety device:** disk (9) centrifugal weights locate on housing (5) (Fig. 7) inside the balancer if an over-acceleration occurs. If the block is due to either load detachment or to knob (1) or control from the floor (48) faulty operation, either disk (9) or housing (5) could be damaged.

In case of block, always operate according to the extraordinary maintenance instructions stated on this manual.

- **Protection against load dropping due to a breakage of the spring:** under normal conditions, the spring of the assembly (13) torsion moment, through gear (7), keeps screw (45) pushed upwards and this, by means of pin (43) keeps the locking pin (8) locked. (Fig. 8). The spring of the assembly (13) breakage enables spring (42) to lower pin (43) thereby releasing the drum lock (8) which blocks disc (9) rotation, preventing from the load descent (Fig. 9).

Adjustment for an insufficient load can also block disk (9), preventing drum (13) from rotating, by stopping it at the higher part of the stroke; this is shown by the screw (45) protrusion for approx. 4 mm (Fig. 9 C). To avoid this problem proceed as follows:

- 1) pull up cam (4) (Fig. 6)
- 2) increase the balancer load (turn clockwise screw (45))
- 3) move and lock clamp (29-30) to limit the upwards stroke to the minimum.

If this does not remove the block of the drum of the assembly (13), replace the balancer with one of a lower capacity.

- **To adjust the balancing, use the worm screw (45); to increase capacity, rotate it clockwise, to decrease capacity, rotate it counter-clockwise.**



After adjusting the load, check that cable (14) runs for its full length and is not limited by a fully loaded spring of the assembly (13).

- During working the cable must not unwind its total length. It must stop at least 50 mm before the lower limit of the stroke. (Fig 10).
- If necessary move and lock clamp (29-30) to limit the upwards stroke. (Fig. 10).
- To lock the load at the desired height, turn knob (1) in C (Fig. 5).
- In the version with control from the floor (Option "B") operate the handgrip (48): **by pulling the RED side down the load locks at the desired height, by pulling the GREEN side down the stroke of the balancer is released.**



Knob (1) or cam (48) should reach stable position of stroke end.

Do not unlock the balancer when the cable is outside and not attached to the load.

USING THE BALANCER

- When the balancer with its load is installed, check that working conditions are correct (smooth movement with minimum effort and no anomalous noises).
- For a correct and safe use periodically check the status of the upper attachments, hook (17) and safety connection (31) (if screws are used, the status of self locking systems and/or split pins should be checked. If in doubt, replace them). Check also the status of the supports installed by the customer and the status of the safety suspension (S).



Periodically check that parts under strain (hook, cable, balancer suspension parts and connections to the tool) are safe and not weakened by wear.

Verify that hooks (31) and (17) spring operates regularly and that safety tank is well sticking. Carefully check the status of the cable on its full length (Fig. 9). In case of type A faults (breakage of a few single wires) the cable can still work. In case of either type B or C faults (breakage of a strand): the cable must be immediately replaced.

INSTALLED BALANCER LITTLE MAINTENANCE

- Lubricate cable (14), cam (1) (or the control from the floor device (48)): in an industrial factory use grease BEACON 325 (ESSO) or similar



In a food industry use proper grease (special balancers should be required).

EXTRAORDINARY MAINTENANCE TO CARRY OUT KEEPING THE BALANCER OUT OF LINE



Before removing the load from the balancer, cable (14) must be fully retracted inside the balancer with the shock absorber (28) fitted against guide (27). The cable extended with the spring loaded could rewind at an uncontrolled speed causing injury.

- Remove the balancer from the support with the due caution.



Before touching the balancer inside, carefully check that the spring of the spring-drum assembly (13) is unloaded.

This can be checked in two ways:

- free rotation without effort of the drum by means of cable (14) by holding on cam (4) (Fig. 6)
- screw (45) protrusion for approx. 4 mm, as shown in (Fig. 9).

Balancer disassembling:

- Remove circlip (22), screws (40); pull up housing (5); totally unwind cable (14); remove shaft (11) by using if necessary a plastic hammer.
- Check the spring-drum assembly (13): if the inner spring is broken and the slot guide cable is damaged, it must be entirely replaced. The spring-drum assembly is supplied assembled, lubricated and equipped with bearings. Never open it.
- Check cable (14); in case of A, B or C defaults it must be replaced. (Fig. 11).
- Check disc (9) centrifugal masses (they must be free to move), check springs (37) (they must be in a perfect status and must assure the return of the masses); check that housing (5) is not damaged (Fig. 7).
- The centrifugal safety disc (9) is supplied completely assembled; the sole available spare parts are the springs (37).
- Check the correct functioning of all the locking devices (8 and 38), of the screw (45) and pin (43) (which must axially run and rotate) and check springs (6-6-42) efficiency.

Balancer assemblage:

- Check the free movement of the stop device (A).
- Tighten screw (15) on the end of cable (14) by means of a torque of 20 Nm.
- Lubricate the cable, precisely wrap it up inside the drum of the assembly (13) helicoidal slots, carefully inserting it inside the stop device (A) and carry out the assembling.
- The screws (39) of the safety disc (9) must be tightened by means of a torque of 5 Nm.
- Assemble housing (5) on shaft (11) and couple it to housing (21), then carefully close it; screws (40) must be tightened by means of a torque of 3 Nm.
- When the assembling has been completed, load the spring of the assembly (13) by means of screw (45) holding on the locking pin (8) by means of cam (4) until screw (45) is not in line with housing (5). (Fig. 8B).
- Install the balancer by following the installation instructions stated on this manual. With the load attached, but safely kept on the floor or on a lift truck, adjust the load to reach the desired balancing.

The use of other than TECNA S.P.A. replacements parts may result in safety hazards, decreased performance and increased maintenance, and may invalidate all warranties. Repairs should be made only by authorized trained personnel. Consult TECNA S.P.A..



When the balancer operative life has expired, it must be either removed or recycled according to the present regulations. Do not disassemble the spring-drum assembly (13) as this operation brings some risks.

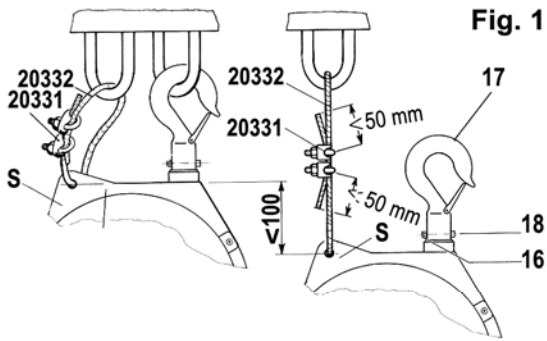
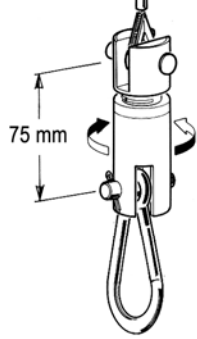
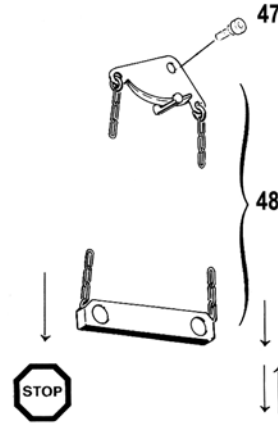

Fig. 1

OPTION B

Fig. 2

Fig. 3



Art. 70477
OPTION RI

Fig. 5

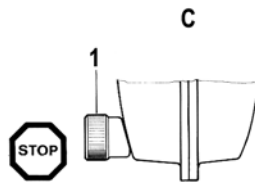
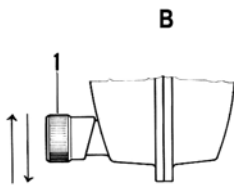

Fig. 6



Fig. 7

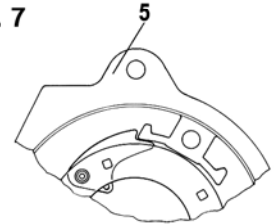

Fig. 8

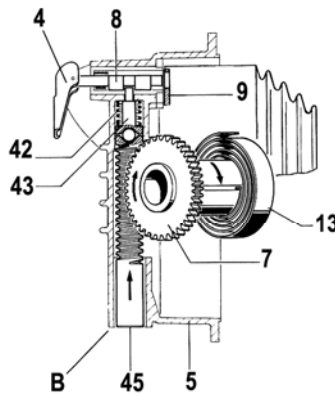

Fig. 9

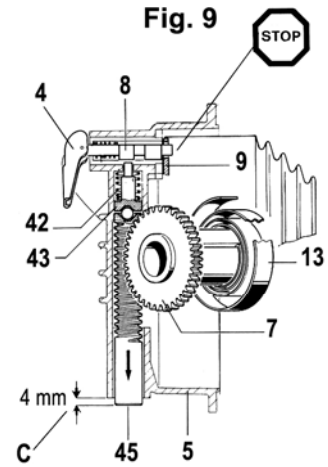

Fig. 10

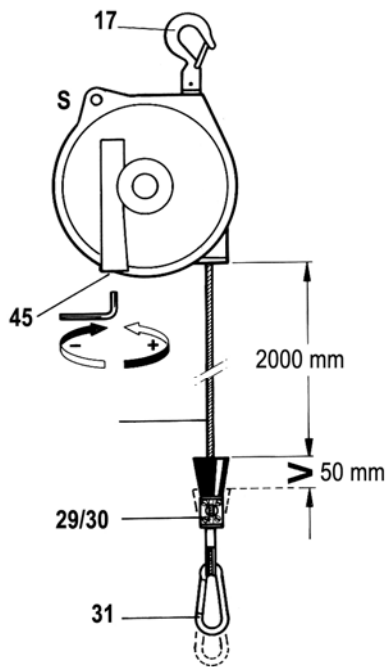
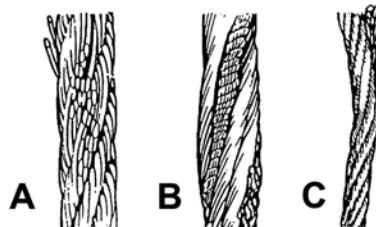
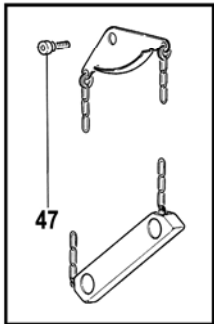
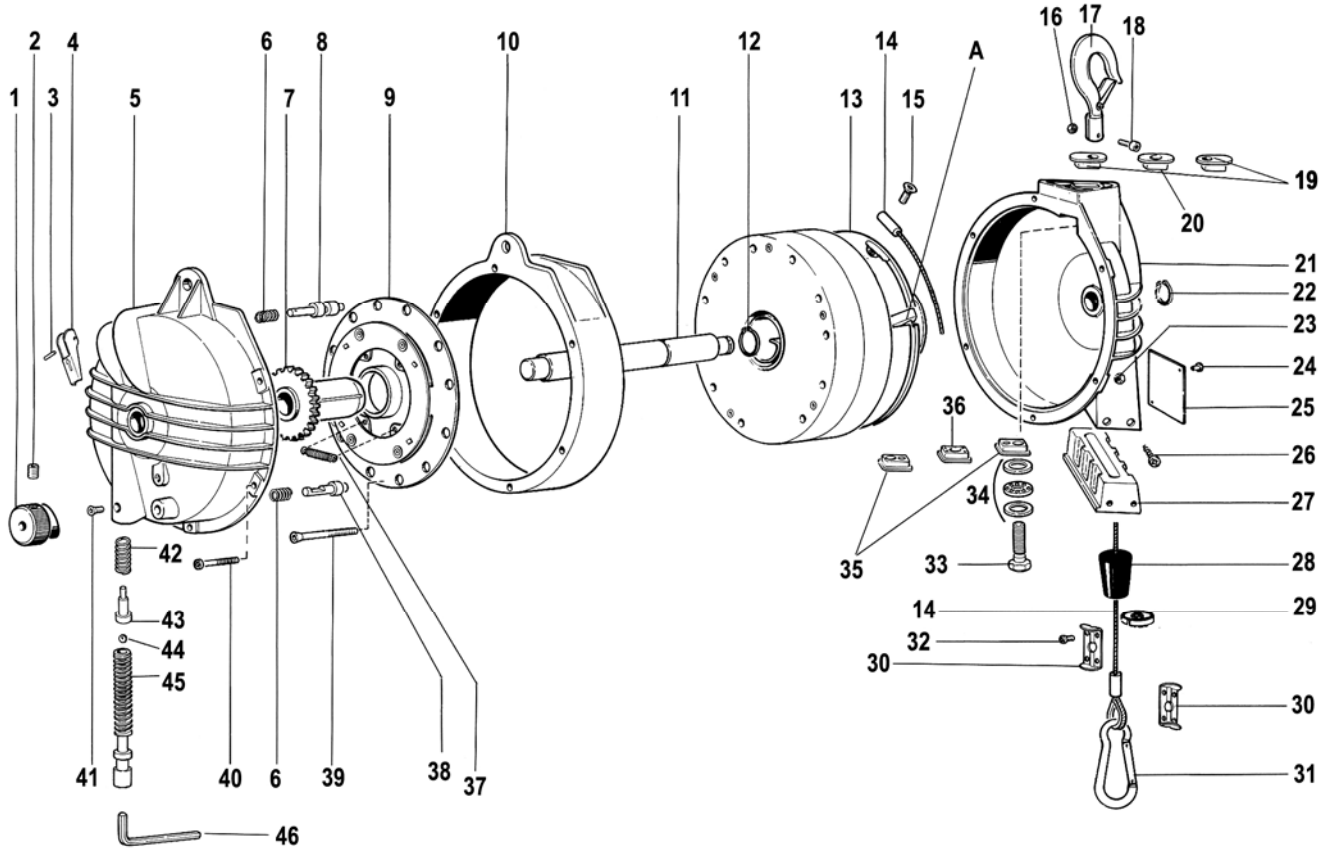

Fig. 11





9361...9363

9364...9367

9368...9371

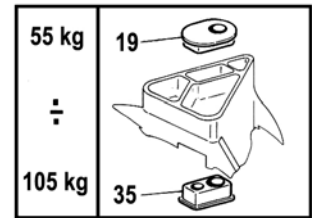
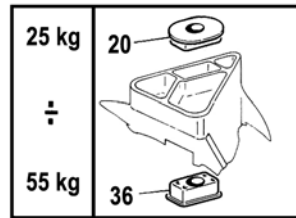
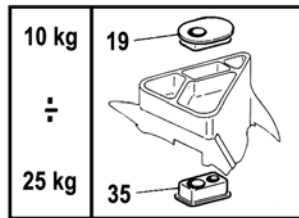

Pos.	Qty	Codice
1	1	30638
2	1	10101
3	1	10496
4	1	31169
5	1	49026
6	2	30348
7	1	9361...9369 30354
	1	9370-9371 38313
8	1	30347
9	1	9361...9369 70081
	1	9370-9371 70165
10	1	9370-9371 44176
11	1	9361...9369 30349
	1	9370-9371 38299
12	1	10160
13	1	9361 70385
	1	9362 70386
	1	9363 70387
	1	9364 70388
	1	9365 70389
	1	9366 70390
	1	9367 70391
	1	9368 70392
	1	9369 70393

Pos.	Qty	Codice
1	1	9370 70394
	1	9371 70395
14	1	31277
15	1	10156
16	1	10691
17	1	70082
18	1	10690
19	1	9361...9363 31221
	1	9368...9371 31221
20	1	9364...9367 31223
21	1	49027
22	1	10036
23	6	10429
24	2	10411
25	1	--
26	4	11069
27	1	38581
28	1	9361...9369 30275
	1	9370-9371 31119
29	1	9370-9371 33033
30	2	33020

Pos.	Qty	Codice
31	1	20132
32	4	10379
33	1	31420
34	1	10542
35	1	9361...9363 31220
	1	9368...9371 31220
36	1	9364...9367 31222
37	2	30352
38	1	32106
39	6	9361...9369 10186
	6	9370-9371 10538
40	6	9361...9369 10187
	6	9370-9371 10685
41	1	10189
42	1	9361...9369 30355
	1	9370-9371 30640
43	1	30356
44	1	10122
45	1	30353
46	1	10270
47	1	30623
48	1	70084

DECLARATION OF CONFORMITY

Name and address of manufacturer:

TECNA S.P.A.
Via Grieco 25/27
40024 Castel S. Pietro Terme (BO)
ITALY

We declare under our sole responsibility for manufacture of the product:

BALANCER

Models:

9361 9362 9364 9365 9366
9367 9368 9369 9370 9371

Serial Number:

FROM 026000
TO 035999

To which this declaration relates is in conformity with the following standard:

DIN 15113

Following the provisions of EEC Directives:

89/392
91/368
93/44
93/68

Name and signature of authorized person:

CASTEL S. PIETRO T. 01/02/2002



Ezio Amadori

BALANCER:

ITEM

SERIAL NUMBER:

CAPACITY:

Kg

STROKE:

mm

TEST:

DATE